

TRAILER RANGE



ECO-6



ECO-8



GR-8



EURO-11



GR-12



GR-12 DRIVE



XL PRO-14

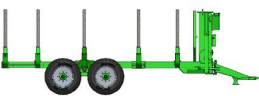

GR-15



HOOKLIFT

BOTEX

Green Range GR-12



UK MADE

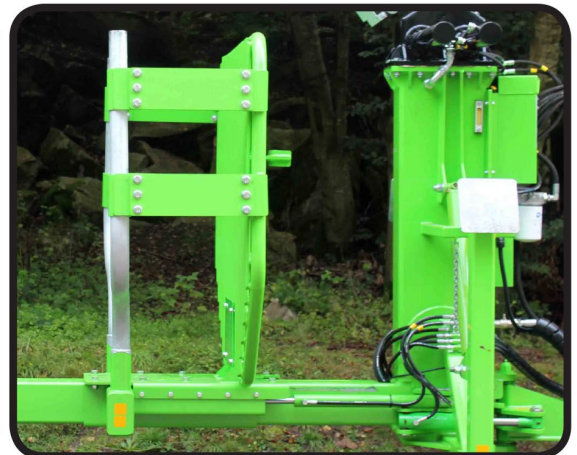

New to the range, this unit has been designed for UK & Irish forests. Strong, nimble and flexible. This trailer also benefits from a Hydraulically Movable Headboard ensuring perfect weight distribution every time.

JAS P WILSON

FOREST MACHINES

Tel: 01556 612233

botex@jaspwilson.co.uk

www.jaspwilson.co.uk

KEY FEATURES



Hydraulic Headboard

Ensure perfect weight distribution thanks to the hydraulic headboard. Controlled in-cab.



Tyres

Large Diameter tyres for increased flotation and reduced drag. Ideal on difficult terrain.

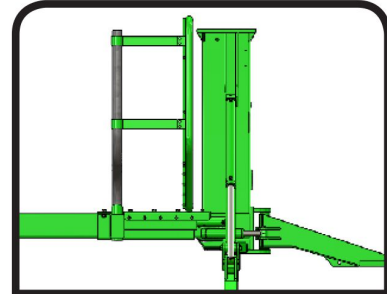

Strength in Design

Innovative design retains the robust Botex build quality, with weight saving elements to minimise ground damage.

Technical Specification	GR-12
Max. Load	12,000 kg
Carrying Capacity	12 m ³
Unladen Trailer Weight (no loader)	2750 kg
Total Length	6610 mm
Total Width	2425 mm
Load Space Area	2.65 m ²
Load Space Length	4440 mm
Bunks/Posts	4/8
Ground Clearance	670 mm
Drawbar Type	Steering
Wheel Size	560/45/22.5
Tyre Ply	16
Brakes	4 Wheel Hydraulic
Road Lights	As Standard
Loader Options	Botex 560, 573 or 583

TECHNICAL DIAGRAM

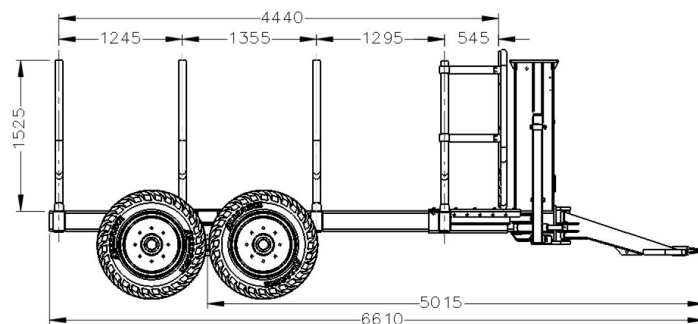
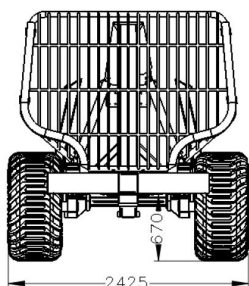

OPTIONAL EXTRAS

There are a number of options available, please contact us and discuss your requirements.